



PALADIN®

BRADCO

TRENCHERS

Selection, Innovation, Performance

Your One-Stop Shop
for Hydraulic Tools
and Attachments



STANLEY
Infrastructure

INDUSTRIAL TOOLS & ATTACHMENTS

 PALADIN  STANLEY  LABOUNTY  PENGO

330 TRENCHER



Bradco® 330 Trencher requires rear hydraulics to run machine. Comes with light/medium duty boom and crumber with replaceable wear strips. Easy installation and operation.

- Category 1ASAE S217.12 standard, 3-point mount for 15-30 PTO HP hydrostatic tractors
- 14" discharge auger
- 30" & 36" digging depth available to fit most applications
- 38,000 lb 1.654" anti-back flex-chain for tooth pattern versatility to support many soil types and conditions
- Compatible with model 615 chains
- ASAE S278.6 standard quick attach compatible
- Support stand is a standard feature

SPECIFICATIONS

TRANSPORT

A. Trench Depth with Auger at 65° Digging Angle	30"	36"
B. Chain Width	3.0"	3.0"
	4.5"	4.5"
	6.0"	6.0"
	8.0"	8.0"
C. Recommended Trenching Angle	65°	65°
D. Headshaft Height (Auger Touching Ground)	8.5"	8.5"
E. Overall Length	73"	79"
F. Overall Width	38"	38"
G. Overall Height	29"	29"
H. Spoil Discharge Reach	21"	21"
L. Length from 3-Point to Headshaft (center of gravity)	24"	24"
M. Transport Angle	48°	48°
Weight with 6" x 36" chain, boom & crumber	650 lbs	

HYDRAULIC SYSTEM

Operating Hydraulic System	2000 to 25000 PSI
Rear PTO RPM Rating	540 RPM
Rear PTO HP Rating	15 to 30 HP

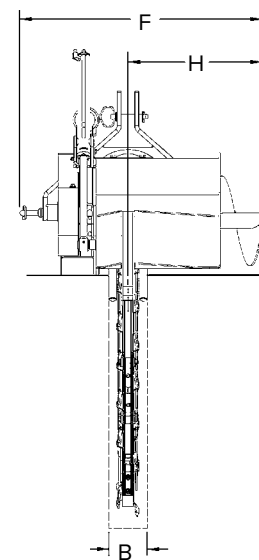
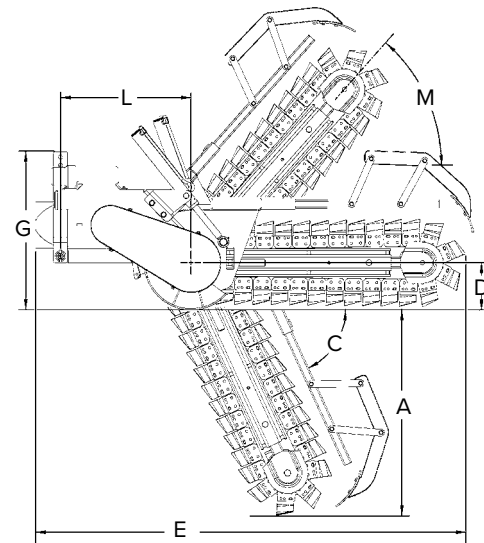

612 TRENCHER



Bradco® 612 Trencher uses a Category I, 3-point mount for 20-45 PTO HP hydrostatic tractors.

- PTO shaft-drive with heavy duty slip clutch for overload protection
- Gearbox drive with chain reduction to the headshaft giving productive digging chain speed
- 24" discharge auger, places dirt well away from the trench
- Several tooth options available
 - CUP
 - SHARK
 - ROCK & FROST
- 50,000 lb 2" anti-back flex-chain

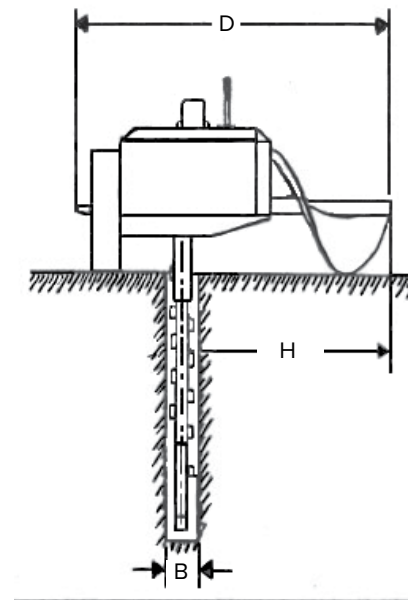
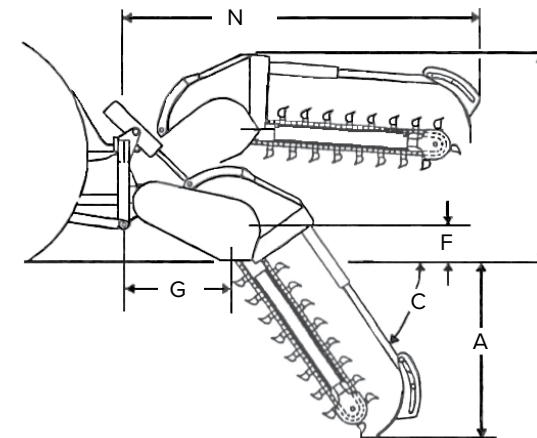

SPECIFICATIONS

3-POINT MOUNTING

A. Trench Depth	30", 36", 48", 60"
B. Trench Width	6", 8", 10", 12"
C. Trenching Angle	65°
D. Auger Diameter	24"
E. Width	43"
F. Headshaft Height (auger at grade)	12"
G. 3-point Length to Headshaft	24"
H. Spoil Discharge Reach	29"
L. Transport Height	varies
M. Center of Trencher to End of Auger	27"
N. Trencher Length with 4' boom	96"

MAXIMUM TRENCHING DEPTHS BASED ON TRENCH WIDTH

6" wide	60" deep
8" wide	48" deep
10" wide	36" deep
12" wide	30" deep
Digging Chain Specifications	
Double standard, anti-backflex	50,000 lbs
Standard chain pitch	2"

*Requires hydraulic power outlets at rear of tractor or valve kit required

625 TRENCHER

Bradco® 625 Trenchers feature fixed length booms with spring-loaded, self adjusting idler with full rock guards.

- 30", 36", 42" & 48" digging depth available to fit most applications
- Heavy-duty boom & crumber with replaceable wear strips
- Allows tight fit with single side spoil augering
- Replaces dedicated machines at a fraction of the cost
- Several tooth options available
 - CUP
 - SHARK
 - ROCK & FROST
- 50,000 lb 2" anti-back flex-chain for tooth pattern versatility to support many soil types and conditions
- Two position manual side shift mounting with optional infinite position using hydraulic side shift cylinder assembly

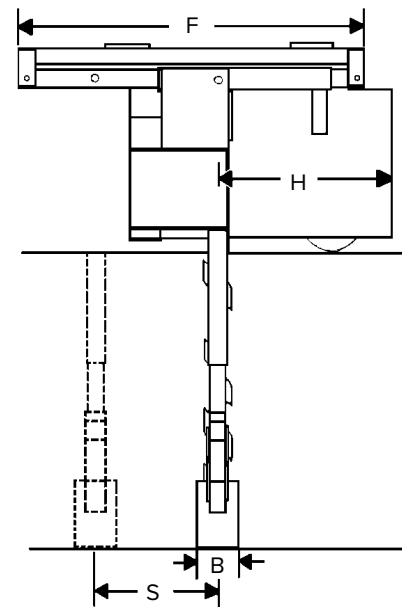
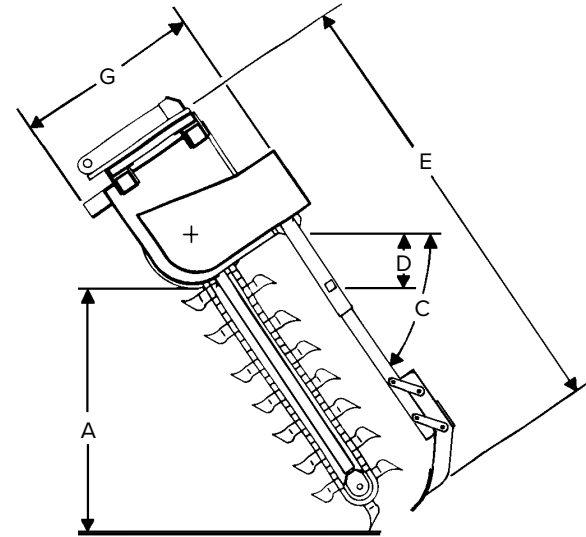

SPECIFICATIONS

BOOM SIZE	30"	36"	42"	48"
A. Trench Depth with Auger at 65° Digging Angle	30"	36"	42"	48"
B. Chain Widths	6", 8", 10", 12"	6", 8", 10"	6", 8", 10"	6", 8"
C. Recommended Trenching Angle	65°	65°	65°	65°
D. Headshaft Height (Auger Touching Ground)	8"	8"	8"	8"
E. Overall Length	66"	73"	79"	86"
F. Overall Width	53"	53"	53"	53"
G. Overall Height	32"	32"	32"	32"
H. Spoil Discharge Reach	18"	18"	18"	18"
S. Side Shift, Right of Center	17"	17"	17"	17"

HYDRAULIC SYSTEM

GPM Requirements	Min 14 / Max 22
Operating Pressure	2000 to 3000 PSI

640 TRENCHER

Bradco® 640 Trencher features 5 motor options to match the flow of many skid-steer loaders. It has a two position manual side shaft mounting.

- 30", 36", 42" & 48" digging depth available to fit most applications *60" high flow only
- Two-position side-shift
- Fixed length booms available featuring spring-loaded, self adjusting idler with full rock guards
- Heavy-duty boom & crumber
- Allows tight fit with single side spoil augering
- Replaces dedicated machines at a fraction of the cost
- Several tooth options available
 - CUP
 - SHARK
 - ROCK & FROST
- 50,000 lb 2" anti-back flex-chain for tooth pattern versatility to support many soil types and conditions
- Two position manual side shift mounting with optional infinite position using hydraulic side shift cylinder assembly

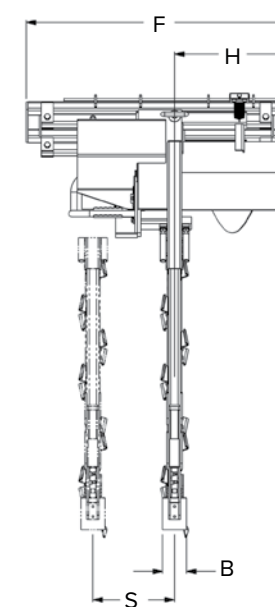
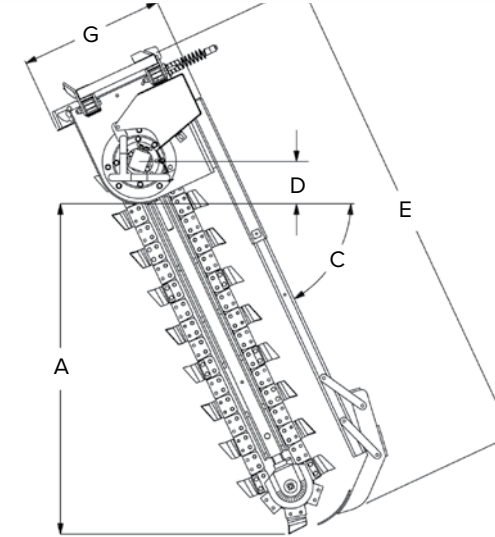

SPECIFICATIONS

BOOM SIZE	30"	36"	42"	48"	60"
A. Trench Depth with Auger at 65° Digging Angle	30"	36"	42"	48"	60"
B. Chain Widths	6", 8", 10", 12"	6", 8", 10", 12"	6", 8", 10"	6", 8"	6"
C. Recommended Trenching Angle	65°	65°	65°	65°	65°
D. Headshaft Height (Auger Touching Ground)	8"	8"	8"	8"	8"
E. Overall Length	66"	73"	79"	86"	94"
F. Overall Width	53"	53"	53"	53"	55"
G. Overall Height	32"	32"	32"	32"	57"
H. Spoil Discharge Reach	18"	18"	18"	18"	24"
S. Side Shift, Right of Center	17"	17"	17"	17"	17"

HYDRAULIC SYSTEM

GPM Requirements (standard flow)	14 to 24
GPM Requirements (high flow)	25-44
Operating Pressure	2000 to 3300 PSI

655 ROCK TRENCHER

CHAIN OPTIONS

When the job requires trenching through asphalt, frozen ground, fracturable rock, or extremely compacted soils, the Bradco 655 Rock Trencher will handle the conditions with ease.

- Mount to skid-steer loaders
- Does not require a dedicated power unit
- Heavy duty crumber & safety bar
- High flow
- Tooth every station rock chain
- 2" pitch, 43,000 lb. anti-back flex chain for maximum performance and life
- Double standard chain for tooth pattern versatility
- Heavy duty chain reduction drive system amplifies torque to cutting chain
- High torque hydraulic motor for maximum digging power
- Low profile dirt shield for better operator visibility
- Built-in skid shoe to provide positive depth control for auger
- Pivoting crumber shoe to assist with loose soil removal

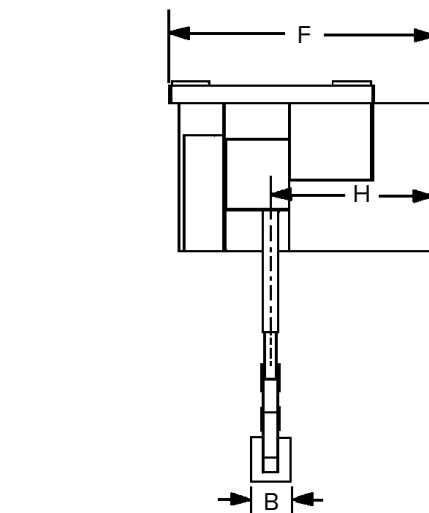
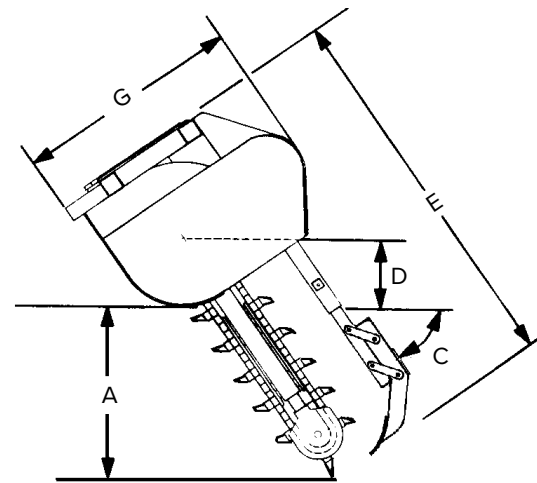

SPECIFICATIONS

BOOM SIZE	30"	36"
A. Trench depth with auger at 65° digging angle	30"	36"
B. Chain widths	8"	6"
C. Recommended trenching angle	65°	65°
D. Headshaft height (auger touching ground)	11.25"	11.25"
E. Length (overall)	58"	64"
F. Width (overall)	43"	43"
G. Height (overall)	37"	37"
H. Spoil discharge reach	27"	27"

Hydraulic Motor	35 cu. in. displacement	35 cu. in. displacement
-----------------	-------------------------	-------------------------

HYDRAULIC SYSTEM

GPM requirements	min 22 / max 40	min 22 / max 40
Max operating pressure psi	3500	3500

TRENCHER CHAIN & TEETH ASSEMBLIES

Full Shark Tooth Chain (100% shark teeth)

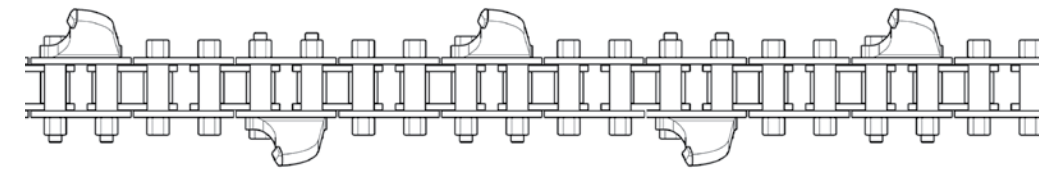

70/30 Combination Chain (aggressive shark style/cup teeth)
2" Pitch

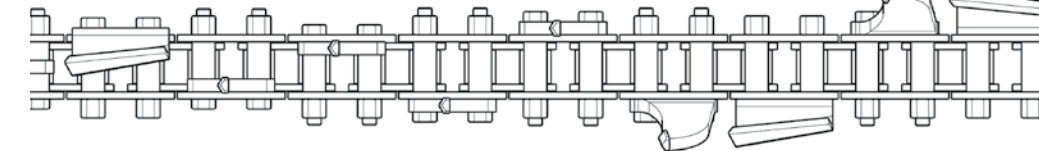

50/50 Rock & Frost Chain
2" Pitch

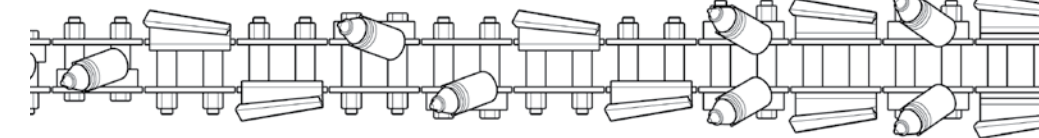

Tooth Every Other Station (TEOS)
2" Pitch 50,000#

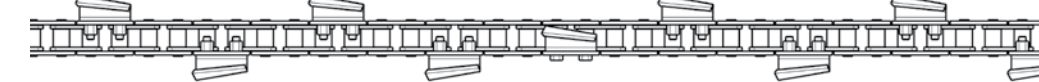

Tooth Every Station (TES)
2" Pitch 50,000#

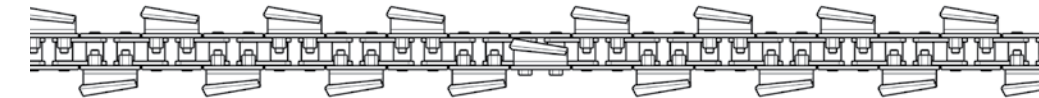

CHAIN WIDTHS

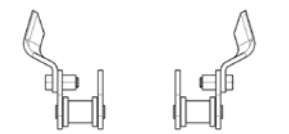

4" wide chain

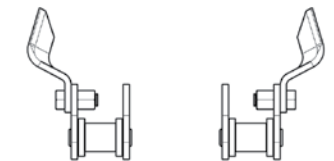

6" wide chain

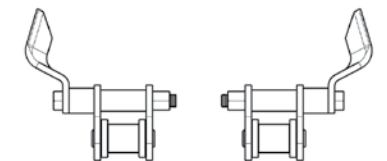

8" wide chain

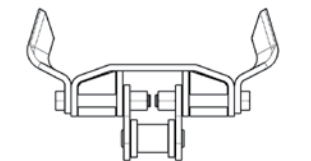

10" wide chain

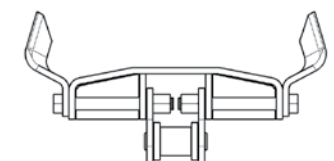

12" wide chain

PERFORMANCE. PARTNERSHIP. SELECTION.



STANLEY
Infrastructure

6430 SE Lake Rd.
Portland, OR 97222
833.723.1843
www.STANLEYinfrastructure.com

