



Grapple Bucket/Rake

Rugged. Versatile. Dependable.

JRB Grapple Bucket/Rake by Paladin are designed to efficiently load tires, clean-up debris and work in land clearing and trash handling applications.

The JRB Grapple Bucket/Rake attaches to wheel loaders as a pin-on attachment and is compatible with JRB's Quick Coupler System.

Six models range in capacity from 1.5 cubic yards to 6 cubic yards. The "C" shaped radius allows small debris to fall through the bottom shell.

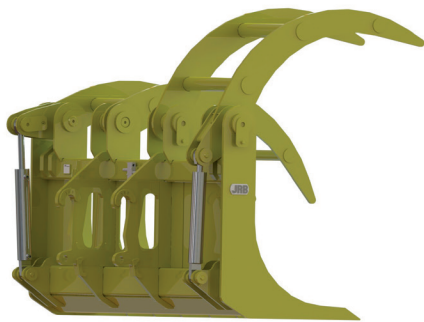

Dual hydraulic cylinders allow independent actuation of each cylinder for clamping uneven loads.

"C" shaped radius

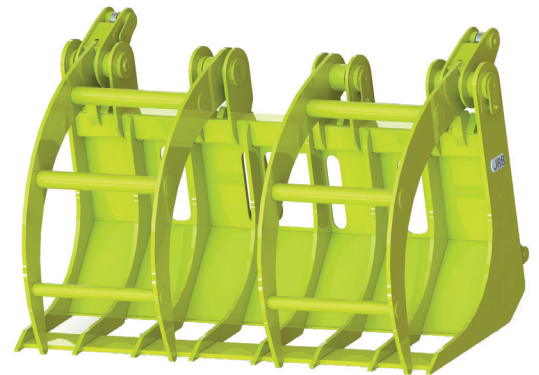

Multi-tine grapples allow for better material retention.



Grapple Bucket/Rake

- Efficient design for loading tires, land clearing, and trash handling
- “C” shaped radius excretes small debris through bottom shell
- Multi-tine grapples allow for better material retention
- Dual hydraulic cylinders allow independent actuation of each cylinder for clamping uneven loads
- Optional sidebars available
- Available as pin-on or compatible with JRB’s Quick Coupler System
- Third function loader hydraulics and jumper hose kit required for operation

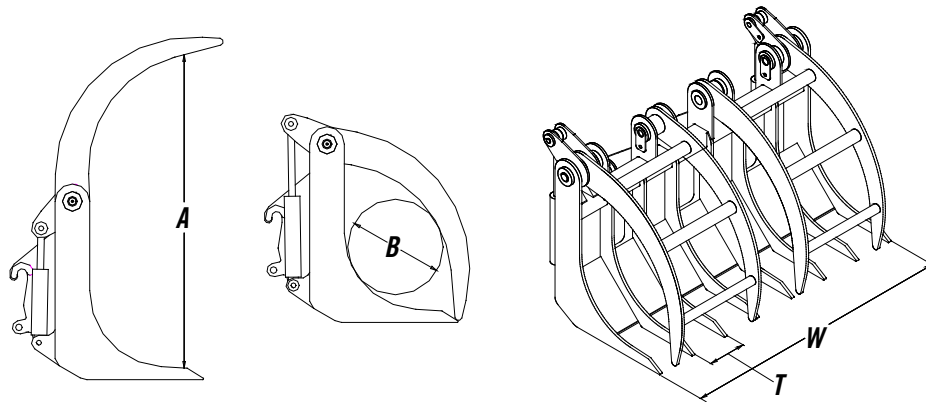

| Class | 100 | 200 | 300 | 500 | 600 | 700 |
|--------------------------|------------|------------|------------|------------|------------|------------|
| A. Catalog Number | 150GBR | 225GBR | 300GBR | 350GBR | 450GBR | 600GBR |
| B. Capacity (Cubic Yard) | 1.50 | 2.25 | 3.00 | 3.50 | 4.50 | 6.00 |
| D. No. of Tines | 8 | 8 | 8 | 8 | 9 | 10 |
| “A” Maximum Opening | 61.35” | 71.42” | 74.83” | 74.83” | 100.89” | 119.59” |
| “B” Minimum Opening | 20.99” | 26.39” | 28.94” | 28.94” | 35.32” | 45.35” |
| “T” Tine Spacing | 12.25” | 13.25” | 13.86” | 13.86” | 14.14” | 12.69” |
| “W” Width | 92.00” | 94.00” | 99.00” | 99.00” | 113.50” | 117.50” |
| Weight | 1,822 lbs. | 2,326 lbs. | 4,693 lbs. | 4,723 lbs. | 7,170 lbs. | 8,500 lbs. |



“Paladin attachments have the **durability** and performance I can always count on.”
Jim W., Construction Contractor